

Wireless IR Barrier User Manual(V2.0)

Summary

The wireless IR barrier is designed for preventing intruders from a protected area by crossing the IR line between transmitter and receiver. Easy installation without wires, more suitable for the places which aren't good for wiring.

Features

1. Definitely wire-free design, easy to install and operate.
2. Low voltage consumption, long battery life.
3. Fully-sealed PC tube adopted, well against dust or water.
4. IP65 approved.
5. Low voltage reminding. If turning to 2.9V, low-voltage signal will be sent to alarm host.
6. 433MHz wireless coding.
7. Lightning protection design, can avoid being struck by lightning.

Product Structure

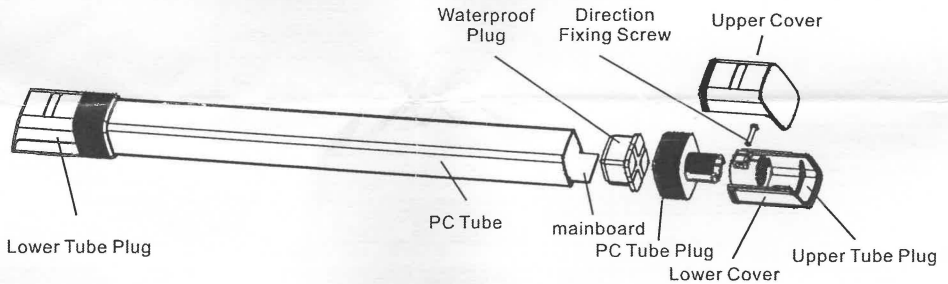
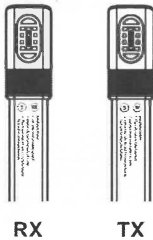

Figure 1

Installation Precautions

1. Pay attention to the alignment direction to prevent water,



Caution:

1. This side must be upward,
2. The distance between RX and TX is $\leq 10\text{m}$
3. This side is the back side, RX and TX must be installed face to face and no obstacles between them

2. Prevent the strong light which may cause false alarm, do not install at the strong light or direct sunlight

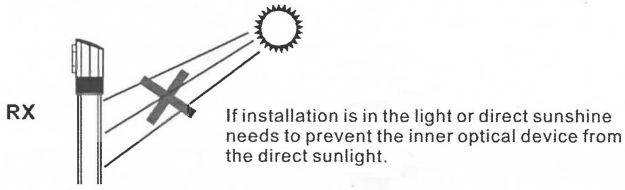

3. To install two pairs or more pairs wireless barriers, in order to avoid the disturbance of the infrared signal from same channel, install as below:

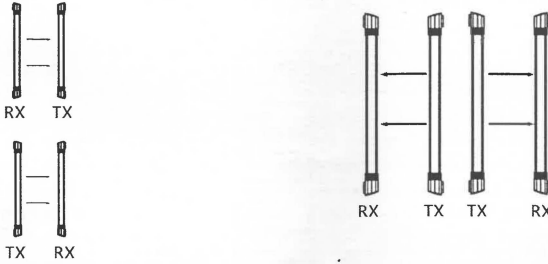

Installation Instructions

1. Take off the upper tube plugs and waterproof rubber plugs then pull out PCB.

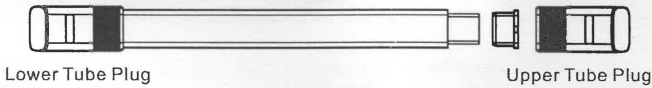

Figure 2

2. Function Setting

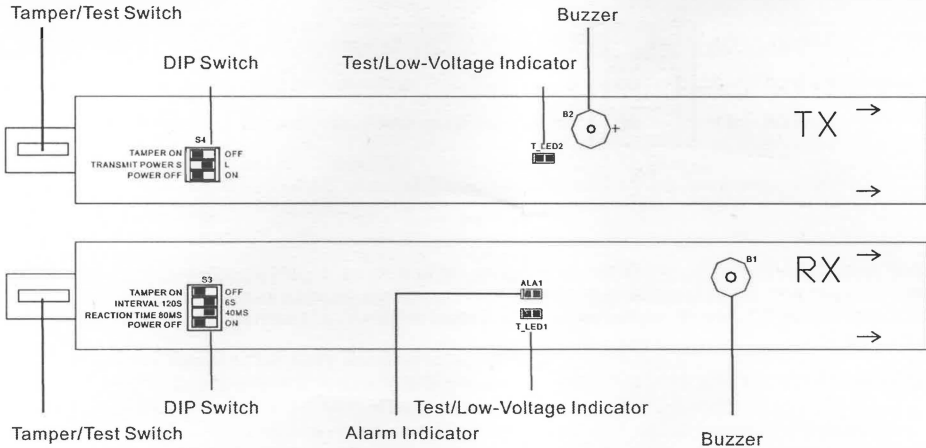

Figure 3

TX S4	Anti-Tamper	TAMPER	ON		OFF	On:Enabler anti-Tamper
		TAMPER	ON		OFF	Off:Disable anti-tamper
	Transmission power	TRANSMIT POWER	S		L	S:Small power for detection distance less than 5m
		TRANSMIT POWER	S		L	L:large power for detection distance from 5m to 10m
	Power	POWER	OFF		ON	OFF:Power off
		POWER	OFF		ON	ON:Power on

RX S3	Anti-Tamper	TAMPER	ON		OFF	On:Enabler anti-Tamper
		TAMPER	ON		OFF	Off:Disable anti-tamper
	Alarm period	INTERVAL	120s		6s	Alarm period:120s
		INTERVAL	120s		6s	Alarm period:6s
	Interruption period	REACTION TIME	80ms		40ms	Interruption period:80ms
		REACTION TIME	80ms		40ms	Interruption period:40ms
	Power	POWER	OFF		ON	OFF:Power off
		POWER	OFF		ON	ON:Power on

3. When power on, set RX/TX DIP on(as below), insert PCB into PC tube, put the plug in and cover the upper tube plug.

(Caution: do not oppose the upper or lower of the PCB.)

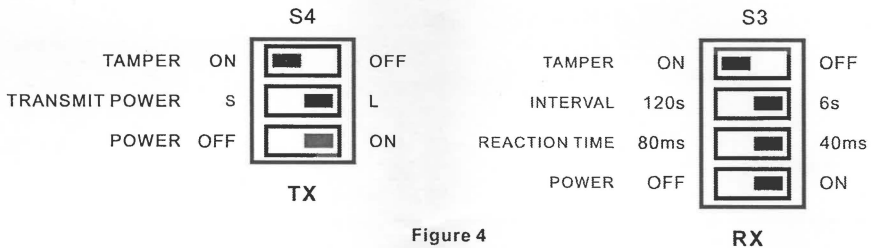
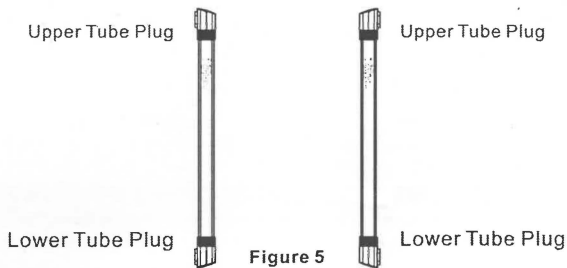

Figure 4

4. Drill installation holes by $\phi 6$ driller on the wall, fill in with equipped plastic expansion screws, then fix upper and lower installation base by M4*25 screws. Please keep TX and RX in same horizontal plane. (Upper plug tube must be installed on the up side while lower plug tubes on the lower side.)



5. Remove upper cover of lower tube plug for TX and RX, it is entering alignment mode after 4 beeps. Adjust it until buzzer doesn't beep. It enters normal working mode after well-alignment.

Note:

- RX will exit alignment mode automatically after 1 minutes failure.
- RX re-entering alignment mode by putting back and remove upper cover of lower tube plug again, try the buzzer till stop beep.
- TX will exit alignment mode putting back upper cover of lower tube plug.

6. Well screws the fixing directions after alignment, put back the upper cover of upper/lower tube plugs, try to active it, alarm triggered.

7. Coding to alarm host:

Under normal working mode(no alarm triggered or no blocks between TX and RX within 6s/ 120s), alarm host is entering wireless coding mode. Block the barrier once, trigger alarm. It is well coded now.

Product Structure

Alarm current	0.3mA	
Battery life	3 years	
Maximum detection distance	10m	
Wireless frequency	433 MHz	
Working current	RX <100μA /TX <100μA	RX <120μA /TX <120μA
Interruption period	≤40ms	
Dimensions	650mm(L)*39mm(W)*39mm(H)	430mm(L)*39mm(W)*39mm(H)
Waterproof grade	IP66	
Wireless transmission distance	100m in open area	
Working mode	3 options(interruption of all 4 beams or upper 2 beams or below 2beams)	

Troubleshooting

1. Can't align well

- Check power if it is on.
- Test battery voltage of RX and TX, change 2 new batteries if they are lower than 2.9V (Battery model: ER14505 lithium)
- Check if anti-tamper is enabled.
- Check holder for lens if it is loosen, dropped or broken.
- Check PCB is fixed in right direction
- Check if there is any obstacles between TX and RX
- Check detection distance if it exceed

2. Doesn't work if wireless barriers are well blocked

- Buzzer doesn't beep if wireless barriers are blocked, please check TX and RX if they are under normal working mode. Pull out upper cover of lower tube plug of RX, buzzer beeps once a second, it is found out that wireless barriers are not aligned well, please do alignment again.
- Buzzer beeps while alarm host doesn't receive any signal if wireless barriers are well blocked. Please check the detection distance ensure it is within max range.